

Signatone WL-350-LE 300mm Semi-Automatic Probe System with Local Enclosure for Reliable and Accurate RF, DC/CV, Test Measurements

❖ FEATURES / BENEFITS

Designed for a Variety of On-Wafer Analytical and Semi-Production Applications

- RF applications 2 & 4 port setup
- DC, CV/IV, pulsed -IV applications
- IC Design / test verification Ambient, +300°C
- -60 °C to +300 °C when use with Local Enclosure EMI / RFI / Light-Tight Shielding

Local Enclosure for Accurate Measurements

- Designed for advanced EMI / RFI / Light-Tight Shielding.
- FemtoAmp low-leakage abilities

Product Versatility

- Designed for full or partial wafer probing
- Roll-Out stage for ease of wafer loading
- Active Vibration Isolation table (optional)

Options and Configurations

- Local Enclosure Supports 4x RF + 2x DC or 8x DC MicroPositioner / 4.5" wide probe card
- Available in multiple configurations including a variety of chuck options, DC/RF/High Power positioners, Computer Aided Probes, microscopes, camera's ,...

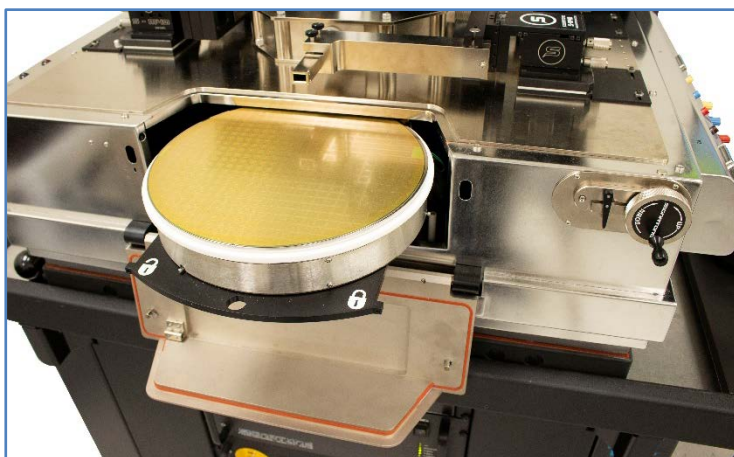
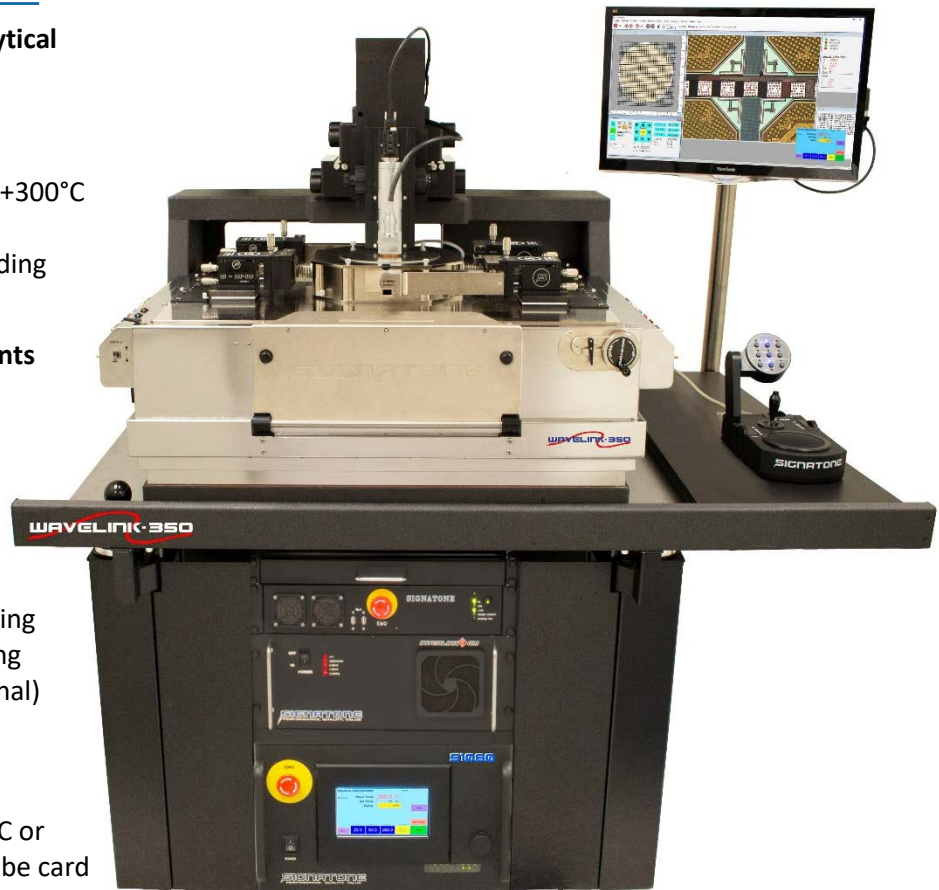

❖ ROLL - OUT STAGE

- Roll-Out Stage designed for easy Loading and Unloading of Wafer Samples and single ICs
- Excellent for use with probe cards and multi probe/complex setups
- Allows easy access to AUX -chucks
- Lock and Un-Lock position indicator
- Presentation 285mm / 95%
- Lock / Unlock indicators
- Simplifies use with Local Enclosure option

❖ SPECIFICATIONS

Chuck XY Stage (Programmable)

Travel range	308 mm x 308 mm (12.126 x 12.126 in)
Resolution	0.5 µm
Accuracy	± 5.0 µm
XY stage drive	Closed-loop high precision servo motor PID control
Speed	Variable Speed XY chuck stage control
Max. movement speed	120 mm / sec.

Chuck Z Stage (Programmable)

Travel range	12.5 mm (0.5 in)
Resolution	0.25 µm
Accuracy	± 2.0 µm
Repeatability	± 1.0 µm
Z stage drive	Closed-loop micro stepper motor
Speed	Variable Mode and Speed selection
Max. movement speed	15 mm / sec.

Chuck Theta Stage (Programmable)

Travel range	± 10° (total range = 20°)
Resolution	0.000035°
Accuracy	< 1.0 µm (measured at the edge of the 300 mm chuck)
Repeatability	< 1.5 µm
Theta stage drive	High resolution stepper motor, rotary encoder feedback system

Roll Out / Loading Stage

Lock / Un-Lock	Software indicates when in Un-Lock Position
Wafer Presentation	95% (see image pg. 1)
Return repeatability	< 1µm

Motorized Microscope Stage (linear)

Movement range	50mm X 50mm (2"x2")
Resolution	0.02µm (20 Nano meters)
Scope lift	101 mm (4") Vertical Pneumatic (Motorized- optional)
Scope lift motorized (optional)	50mm motorized + 50 mm pneumatic / combination = 101mm (4")

❖ **PROBE PLATEN**

Specifications

Material	Nickel Plated Steel (Al optional)
Dimension	L = 783mm x W = 840mm x H = 12.7mm (See drawing)
Chuck to Thermal Shield Separation	Min. 2 mm (Variable Separation with Fine Platen Adjust)
Max. No of Micro Positioners	8x DC or 4x DC + 2x RF or 2x DC + 4x RF or 4x DC + 4x RF
Quick Platen Lift Control (CVL)	Continuous Variable Lift (0 to 3.175 mm)
Contact Repeatability	< 1 μ m (0.04 mils) by Manual Control
RF MicroPositioner mounting	Magnetic or Bolt Down
DC MicroPositioner mounting	Magnetic or Vacuum
Thermal Isolation (Optional)	Platen Temp = +15 °C to +40°C /chuck @ -60 °C to +300°C

Universal Platen Designed for Multiple Probe Configurations

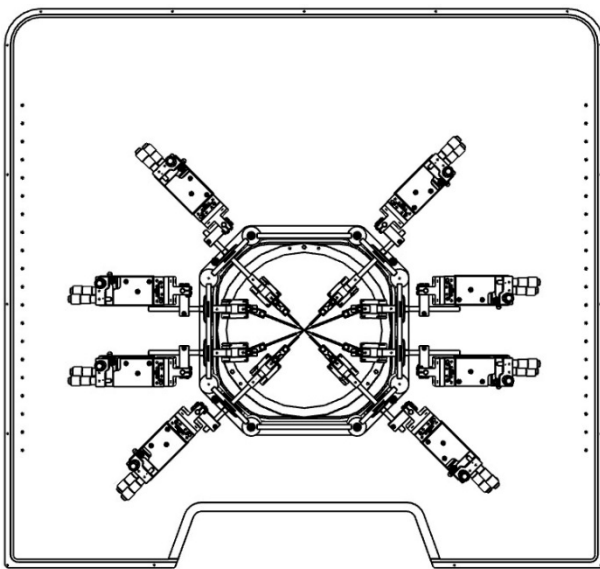

Sample Probe Configured with 8 DC Probes

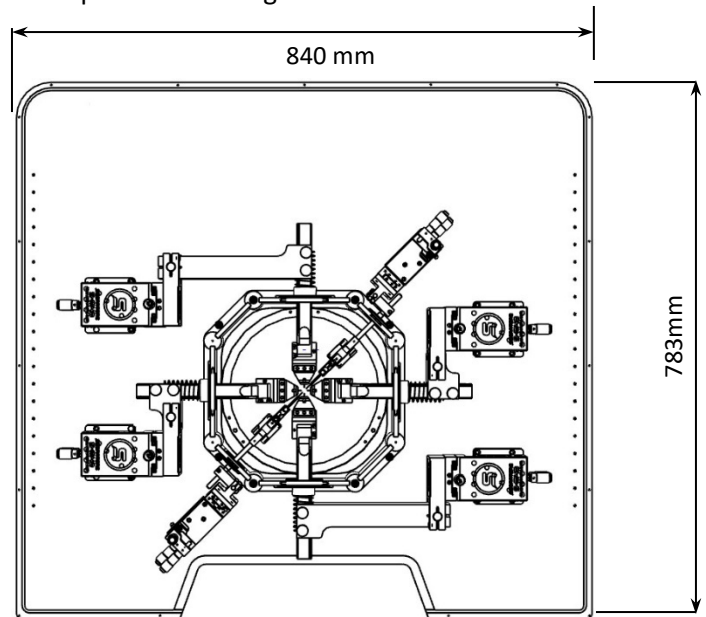

Sample Probe Configured with 4 RF + 2 DC Probes

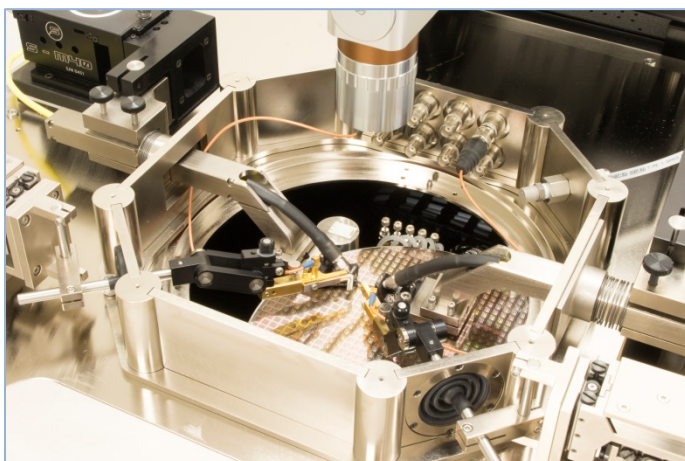

Sample Probe Configured with 2 RF + 2 COAX Probes

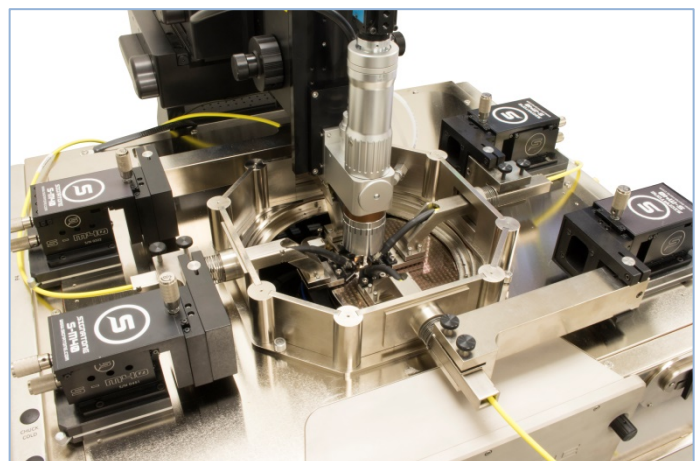

Sample Probe Configured with 4 RF Probes

❖ ONE PLATEN x 4 BENEFITS

Signatone Multi Benefit Ergonomically Correct Platen Adjust and Features:

- “Quick Lift” with CVL for easy probe to pad separation and alignment
- “Fine Adjust” for Probe card and variable Chucks and DUT thickness setup
- “Position Lock” allows for secure “lock” of user defined platen height setup
- “Thermal Isolation” maintains a safe temperature of probes and platen surface while chuck is at extreme temperatures (optional)



Platen “Quick Lift”



Platen “Fine Adjust” and
“Position Lock”

❖ Local Enclosure

Signatone’s Local Enclosure is a high performance environmental chamber that provides an excellent EMI shielded and light-tight environment for low noise and low capacitance measurements. Local Enclosure accommodates 4-port RF or 8-ports DC/Kelvin and connector panel or a combination of RF/DC. The Signatone “Top Hat” provides for easy reconfiguration of Micro positioners, cables, connectors and additional customer defined fixtures allowing multiple setups while maintaining ease of use

Local Enclosure Electrical Specifications

EMI shielding	> 30 dB (typical) @ 1 kHz to 1 MHz
Light attenuation	≥ 130 dB
Spectral noise floor	≤ -180 dBVrms/rtHz (≤ 1 MHz)
System AC noise	≤ 5 mVp-p (≤ 1 GHz)

❖ **DC PROBE –SELECTION GUIDE**

	Coax Probe (C)	Triax Probe (T)	Kelvin Probe (K)
Max voltage	500 V	500 V	500 V
Temperature range	-60 °C to 300 °C	-60 °C to 300 °C	-60 °C to 300 °C
Leakage current	< 50fA	< 20fA	< 20fA
Connectivity	BNC	Standard Triax	SSMC
Connectivity type	Single Coaxial	Single low noise Triaxial	Force/Sense Coax
Characteristics impedance	50 Ohms	50 Ohms	50 Ohms
Residual capacitance	< 80fF	< 80fF	< 80fF
Probe holder material	Brass	Brass	Brass
Probe tips material	Tungsten	Tungsten	Tungsten
Probe tips sizes	0.5 µm – 25 µm	0.5 µm – 25 µm	0.5 µm – 25 µm
Minimum pad size	25 µm x 25 µm	25 µm x 25 µm	25 µm x 25 µm



Coax Probe



Triax Probe



Coax Kelvin Probe

*All leakage tests conducted in an enclosed environment with Keithley 4200, or equivalent, in sampling mode with 10 PLC, auto-ranging. 0.25s interval

❖ **High Voltage/High Current PROBE –SELECTION**

	High Voltage Probes			High Current Probe
Model	HVP-CX-3	HVP-TX-3	HVP-CX-10	HCP 100
Max Voltage	3 kV	3 kV	10 kV	500 V
Max Current	1 A DC/30 A Pulsed	120 mA DC	20 mA DC	10 A DC/100 A Pulsed
Temperature Range	-60 °C to 300 °C	-60 °C to 300 °C	-60 °C to 300 °C	-60 °C to 300 °C
Leakage Current	< 200 pA @ 3 kV, < 5 pA @ 10 V	< 1 pA @ 3 kV, < 100 fA @ 10 V	< 100 pA @ 10 kV	N/A
Connector Type	SHV	HV Triax	UHV Coax	HV Banana
Replaceable Tip	Yes	Yes	Yes	Yes
Probe Material	W	W	W	BeCu or W



HVP-CX-3



HVP-TX-3



HVP-CX-10



HCP-100

❖ RF PROBE –SELECTION GUIDE



Cable Interface

	SP-40A	SP-50A	SP-67A	SP-110H	SP-145
Frequency	DC-40GHz	DC-50GHz	DC-67GHz	DC-110GHz	DC-145GHz
Connector	2.92mm	2.4mm	1.85mm	1.0mm	0.8mm
Tip Configuration	GS/SG/GSG	GS/SG/GSG	GS/SG/GSG	GS/SG/GSG	GSG
Pitch Range	50μ - 2540μ	50μ - 1250μ	50μ - 1250μ	50μ - 1250μ	50μ - 200μ
Insertion Loss	<.8db	<1.0db	<1.1db	<1.5db	<1.75db
Return Loss	> 18db	>18db	>14db	>15db	>15db

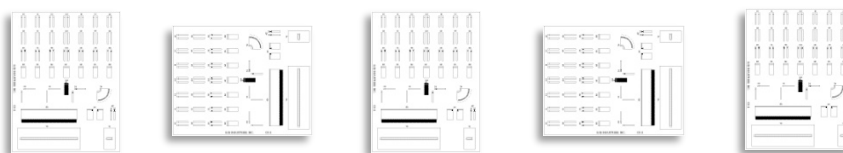

Calibration Substrates

GSG	SP-CS-5	SP-CS-9	SP-CS-10	SP-CS-18
Pad Size	50μ X 50μ 100μ X 100μ 150μ X 150μ	100μ X 100μ	150μ X 150μ	300μ X 300μ
Pitch Range	75μ - 250μ	250μ - 600μ	600μ - 1250μ	1250μ - 2540μ

GS/SG	SP-CS-8	SP-CS-14	SP-CS-11	SP-CS-17
Pad Size	50μ X 50μ 100μ X 100μ 150μ X 150μ	100μ X 100μ	150μ X 150μ	300μ X 300μ
Pitch Range	50μ - 200μ	200μ - 400μ	400μ - 1250μ	750μ - 2540μ

GSG > 110GHz	SP-CS-15
Pad Size	25μ X 25μ
Pitch Range	40μ - 150μ (SOLT) 30μ - 150μ (LRM)



RF Cables

	RFC-40	RFC-50	RFC-67	RFC-110
Frequency Range	DC - 40GHz	DC - 50GHz	DC - 67GHz	DC - 110GHz
Length	4 Ft.	4 Ft.	3 Ft.	*
Connectors	2.92 M – 2.92 F	2.4 M – 2.4 F	1.85 M - 1.85 F	1.0 M - 1.0 F

* Contact Factory

❖ **SYSTEM CONTROLS**

The S1080 thermal chuck controller features touch screen commands, triple safety circuits, and 0.1° resolution. **ProbeMaster** software features thermal control from the probe station.

Hardware accessories including keyboards and mouse can be easily integrated into the table’s instrumentation rack providing greater ease of use, ergonomics, and minimizing the overall system dimensions. System and thermal controllers may also be integrated.

Industry proven precision Joy Stick/ thumbwheel combination, intuitive selector panel for DUT, Microscope, and 1-4 Computer Aided Probes (CAP). LED indicator for active device, Multi-speed thumbwheels offer sub-micron positioning.



❖ **SYSTEM SOFTWARE**

Signatone’s powerful navigation software **ProbeMaster** drives all Signatone semiautomatic probing systems. **ProbeMaster** simplifies navigation to a test site by using arrow keys, wafer graph or *point and shoot* on the live image. The optional vision control module includes *auto align*, *auto start*, *probe exact*, and *sure touch* features. Supports many popular interface protocols * *see supported software platforms*

Go to HOME Location

SW ABORT

WAFER MAP
Programmed Points,
Reports X-Y Position
- Row/Column.
Click and Move to Die
Location, Color Map..

Device Selector
Indicates Wafer,
Scope, Probe 1-4

Wafer “Load / Un-Load”

Program Points
Program Sub-Sites

On-Screen Live Image
Allows Image Capture
and “Point –Shoot”
navigation of Selected
Device

Thermal Chuck
Control Software
0.1° resolution /
RS-232 interface

Joystick Status

MOVE or Step
Direction Keys

❖ **NON-THERMAL CHUCKS**

Standard Wafer Chuck

Connectivity	Coax BNC (m)
Diameter	308 mm
Material	Nickel Plated Brass (gold optional)
Chuck surface	Zone selector knob with Peppered vacuum patterns
Vacuum hole pattern sections(diameter)	22mm, 50mm, 91mm, 135mm, 168mm, 265mm
Vacuum actuation	Selector Knob allows individual activation of vacuum zones
Supported DUT sizes	25mm, 75mm, 100mm, 150mm, 200mm, 300mm
Surface planarity	±6.5μ
Rigidity	<3μ / 10N at edge of the chuck

Electrical Specification (Coax)

Operation voltage	Designed for operation at -200V to + 200VDC
Maximum voltage between chuck top and GND	500 V DC
Isolation	> 150 GΩ

Wafer Chuck (Triaxial)

Connectivity	Triax (m)
Diameter	308 mm
Material	Gold Plated Brass
Chuck surface	Independent Vacuum zones with vacuum rings
Vacuum hole pattern sections(diameter)	0mm, 65mm, 112mm, 162mm, 265mm
Vacuum actuation	Multi-Zone Adjustable Control
Supported DUT sizes	3mm, 75mm, 125mm, 200mm, 300mm
Surface planarity	± 5 μm
Rigidity	<3μ / 10N near at edge of the chuck

Electrical Specification (Triax)

Chuck isolation	Measured @ 10V DC
Force to guard	> 2 TΩ
Guard to shield	> 7 TΩ
Force to shield	> 15 TΩ

Auxiliary Chuck

Quantity	2 AUX chucks (2 nd & 3 rd aux chuck optional)
Position	Independently isolated (located on back left and right)
Substrate Size (L x W)	Max 25mm x 25mm (1"x 1")
Material	Ceramic, Ultem, or NI plated brass
Surface Planarity	≤± 5 μm
Vacuum Control	Controlled independently, separate from wafer chucks

Typical Specifications of *Signatone* Thermal Technology

Nominal Description	300mm Standard Hot	300mm Hot/Cold Triax	300mm Hot/Cold 3kV Triax
Temperature Range	+25 °C to +300 °C	-55 °C to +200 °C	-55 °C to +200 °C
Connectivity	Coax (m)	Triax (m)	SHV Triax (m)
Temperature control method	Liquid Cooled / Resistance heater	Liquid Cooled / Resistance heater	Liquid Cooled / Resistance heater
Coolant	Water	HFE	HFE
Smallest temperature selection step	0.1 °C	0.1 °C	0.1 °C
Chuck temperature display resolution	0.01 °C	0.01 °C	0.01 °C
External touchscreen display operation	Yes	Yes	Yes
Temperature stability	±0.1 °C	±0.1 °C	±0.1 °C
Temperature accuracy	±0.5 °C	±0.5 °C	±0.5 °C
Control method	Low noise DC/PID	Low noise DC/PID	Low noise DC/PID
Interfaces	RS232C	RS232C	RS232C
Optional Interfaces	GP-IB	GP-IB	GP-IB
Chuck surface plating	Nickel	Gold	Gold
Temperature sensor	RTD	RTD	RTD
Temperature uniformity	±0.5 °C at ≤ 200 °C ±1.5 °C at > 200 °C	±0.5 °C at ≤ 100 °C ±2.5 °C at 200 °C	±0.5 °C at ≤ 100 °C ±3.5 °C at 200 °C
Surface flatness	< ±12 µm	< ±12 µm	< ±15µm
Electrical isolation - Coax BNC (m)	150nA	> 5TΩ	> 5TΩ
Heating Rates	25°C to 300°C < 20 min	25°C to 200°C < 22 min	25°C to 200°C < 28 min
Cooling Rates	300°C to 25°C < 16min	25 to -50°C < 45min	25 to -50°C < 50min
Leakage @ 10 V Kelvin Triax (m)	N/A	<100fA	<400fA
Residual Capacitance		<1pF	<1pF
Maximum voltage between chuck top and GND	500V	500V	3kV
3 Safety Circuits	Yes	Yes	Yes
Vacuum Pattern	Rings	Pin hole	Pin hole
Vacuum Zone (DUT Size)	50, 100, 150, 200,300 mm	2, 50, 100, 150, 200,300 mm	2, 50, 100, 150, 200, 300mm

System Controller / Dimensions / Weight / Power Consumption

System Model	W x D x H (mm)	Weight (kg)	Weight (Lbs.)	Power cons. (VA)
S-1080	432 x 483 x 267	20.4	45	2000
TC-II	355 x 711 x 610	50.8	112	1500
2XRC-89HL	559 x 610 x 915	135	297	3700

ERS ULTRA LOW NOISE THERMAL CHUCKS

Specifications of ERS Technology ULN 300mm Chucks

(+300°C available)

Temperature Range	25 °C to 200 °C	-40 °C to 200 °C	-60 °C to 200 °C
Connectivity	Kelvin Triax (f)	Kelvin Triax (f)	Kelvin Triax (f)
Temperature control method	Cooling air / Resistance heater	Cooling air / Resistance heater	Cooling air / Resistance heater
Coolant	Air (user supplied)	Air (user supplied)	Air (user supplied)
Smallest temperature selection step	0.1 °C	0.1 °C	0.1 °C
Chuck temperature display resolution	0.01 °C	0.01 °C	0.01 °C
External touchscreen display (optional)	Yes	Yes	Yes
Temperature stability	±0.08 °C	±0.08 °C	±0.08 °C
Temperature accuracy	±0.1 °C	±0.1 °C	±0.1 °C
Control method	Low noise DC/PID	Low noise DC/PID	Low noise DC/PID
Interfaces	RS232C	RS232C	RS232C
Chuck surface plating	Nickel plated with pinhole surface	Nickel plated with pinhole surface	Nickel plated with pinhole surface
Temperature sensor	Pt100 1/3DIN 4-line wired	Pt100 1/3DIN 4-line wired	Pt100 1/3DIN 4-line wired
Temperature uniformity	< ±0.5 °C at ≤ 200 °C	< ±0.5 °C at ≤ 200 °C	< ±0.5 °C at ≤ 200 °C
Surface flatness and base parallelism	< ±10 µm	< ±10 µm	< ±10 µm
Electrical isolation-Coax BNC (f) (ULN = Triax connection only)	N/A	N/A	N/A
Heating Rates			
25°C	25°C to 150 °C < 15 min	-40 to 25 °C < 8 min	-60 to 25 °C < 12 min
200 °C	25°C to 200 °C < 15 min	25C to 200 °C < 15min	25C to 200 °C < 15min
Cooling Rates*			
200°C	200 to 25 °C < 30 min	200 to 25 °C < 30 min	200 to 25 °C < 30 min
25 °C	N/A	25 to -40 °C < 30 min	25 to -60 °C < 45 min
Leakage (*Ultra-low Noise configuration)	<15 fA/V at 25 °C <30 fA/V at 200 °C N/A	<15 fA/V at 25 °C <30 fA/V at 200 °C <30 fA/V at -40 °C	<15 fA/V at 25 °C <30 fA/V at 200 °C <30fA/V at -60 °C
Capacitance	N/A	N/A	N/A
Maximum voltage between chuck top and GND	500 V DC	500 V DC	500 V DC

*All data are relevant for chucks in ECO mode/ +30% cooling rates for ULN and HV

System Controller / Chiller Dimensions and Power / Air Consumption

System type	W x D x H (mm)	Weight (kg)	Power cons. (VA)	max. Air flow (l/min)
25 to 200 °C	300 x 360 x 135	12	1300	220
-40 to 200 °C	420 x 500 x 1020	140	2400	350
-60 to 200 °C	420 x 500 x 1020	140	2400	350

SYSTEM DIMENSIONS INCLUDING TABLE

WL-350-LE / Vibration Isolation Table / Monitor and Keyboard Mount

Dimensions (L x D x H)	1093x 1085 x 1700 mm	(43 x 42.7 x 66.9 In)
Weight	660 kg	(1455 lbs.)

* Can vary dependent on monitor, keyboard (roll out drawer) position and Microscope selection

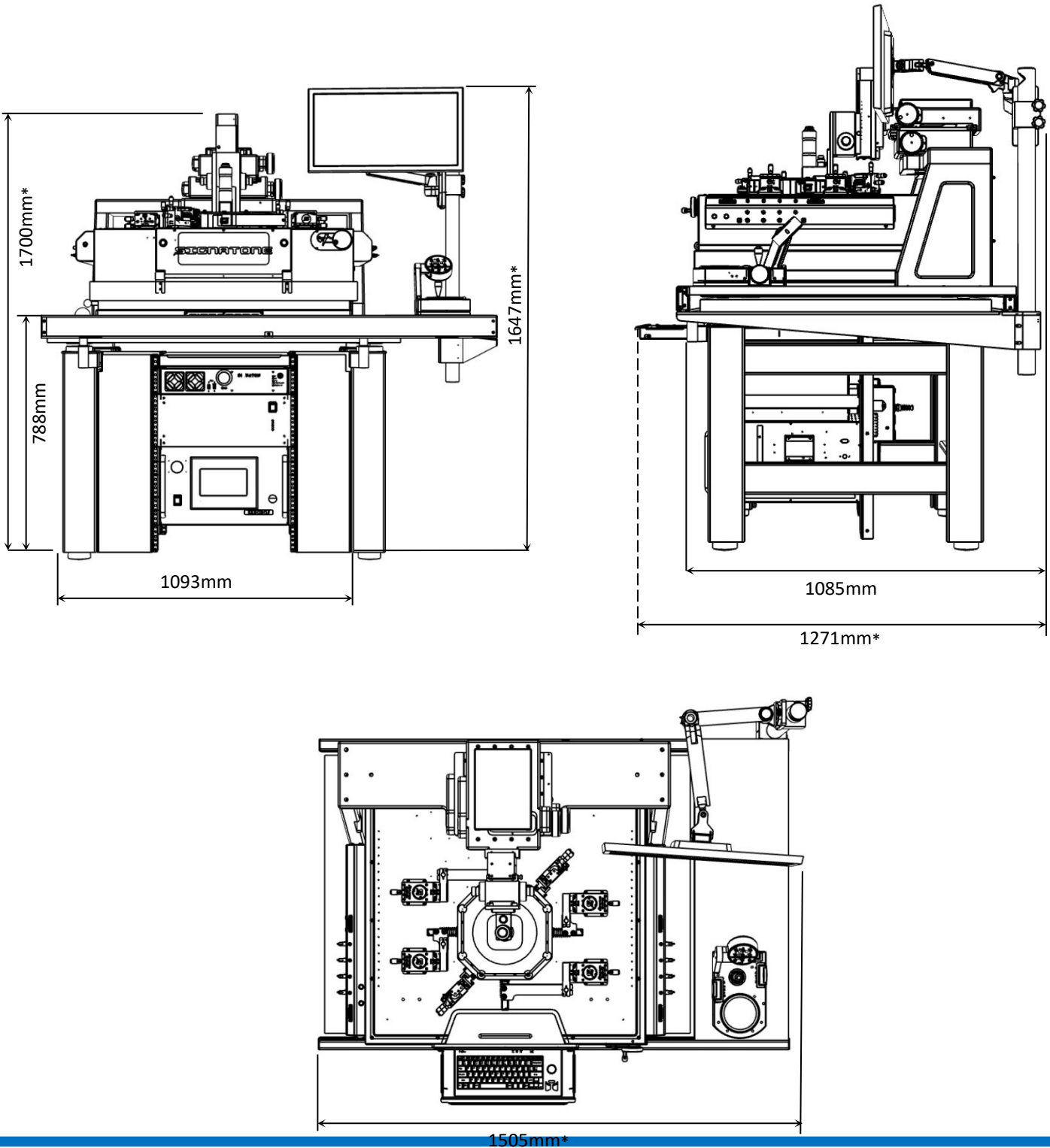

❖ WARRANTY

- Standard Warranty 12 months *
- For Extended Warranty and Service Contracts : Contact Signatone Corp. for more information

* See *Signatone Corporate Terms and Conditions of Sale* for further details.

- **North America:** Sales.NA@signatone.com
- **Europe:** Sales.Europe@signatone.com
- **Asia:** Sales.Asia@signatone.com



