

## High Performance Microwave Probes for RF probing

### ❖ Model SP-67A

- Durable RF probe
- DC to 67 GHz
- Insertion loss less than 1.1 db
- Return loss greater than 14 db
- Measurement repeatability better than -80db
- Individually spring-loaded contacts
- BeCu, Tungsten, Ni-Alloy tips available
- Any pitch from 50 to 1250 micron
- Variety of footprints
- Patented coaxial design
- Available in thirteen different adapter styles



A coplanar probe with patented flexible tips, the MODEL 67A microwave probe sets new standards in microwave probing performance. Using low loss coaxial techniques, the Model 67A achieves an insertion loss of less than 1.1 db and a return loss of greater than 14 db through 67 GHz.

With its individually spring loaded, Beryllium-Copper, Tungsten or optional Ni-Allow tips, the Picoprobe® Model 67A microwave probe provides reliable contacts, even when probing non-planar structures. This reliable low resistance contact is one of the keys to providing highly repeatable measurements. The Model 67A also provides direct viewing of the probe tips for accurate positioning.

The Model 67A can be mounted in various adaptors for use with standard microwave probe stations. Custom mounts are available.

Any pitch (tip spacing) from 25 to 1250 microns may be specified. The probe can be configured with Ground-Signal-Ground (G,S,G), Ground-Signal (G,S), or Signal-Ground (S,G) tip footprints. We recommend smaller pitches with a G,S,G footprint for best results.

### ❖ Flexible Tips for Flexible Probing

Each Model 67A has patented, independently spring loaded tips which ensure a reliable contact to the probing surface. Because the tips are flexible they minimize circuit damage, increase probe life, and most importantly, provide a reliable individually spring loaded contact for each point. With a small amount of overdrive, the point scrubs the surface to make a reliable contact free of dust, dirt, and oxide contamination. A well-appreciated feature of the Model 40A is the ability to view the exact contact area which eases probe placement and allows for the precise positioning necessary for good LRM calibrations. The flexible tips even allow probing of non-planar surfaces such as ceramic substrates and laser diode structures.

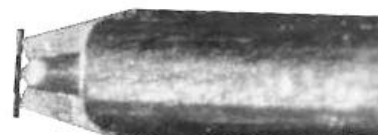

Close up of Model 67A Tips with 150 Micron Pitch almost touching a 50 ohm calibration load.

### ❖ Coaxial Transmission Improves Performance

The Model 67A uses a precision miniature 50 ohm coaxial cable from the probe tips to the connector interface. The coaxial design provides lower loss and less radiation than coplanar designs. The miniature coaxial cable is fabricated from flexible Beryllium-Copper which greatly improves the probe's durability.

### ❖ Probe Cards

The Model 67A as well as all of our RF probes can be mounted on standard 4.5 inch probe cards and/or custom-sized cards to provide a convenient method for testing wafers at high frequencies using standard automatic or manual probe stations. Picoprobe Probe Cards can incorporate our Model 50A probes for RF connections with DC needles for power and low frequency signals



Typical Probe Card with Model 40 Probes.

### ❖ Multi-Contact Wedges

Our unique Multi-Contact Wedge designs accommodate multiple RF and DC contacts on a single, compact adapter. This compact design provides the user with a convenient method for testing wafers at high frequencies using standard automatic or manual probe stations. The user can choose from a variety of wiring options for the DC or power needles and select any combination of 40, 50, 67, and/or 110 GHz RF probes.



Examples of the Multi-Contact Wedge which combines Multiple RF and DC Contacts.

### Model 67A Performance Data<sup>1</sup> G,S,G Configuration

Frequency Range: DC to 67 GHz  
 Insertion Loss: Less than 1.1 db to 67 GHz  
 (.95 db typical)  
 Return Loss: Less than 35 db to 4 GHz  
 (35 db typical)  
 Less than 20 db to 26 GHz  
 (23 db typical)  
 Less than 18 db to 40 GHz  
 (20 db typical)  
 Less than 14 db to 67 GHz  
 (16 db typical)  
 Crosstalk<sup>2</sup>: Less than 35 db to 67 GHz

<sup>1</sup> Specifications are for the P-style Model 67A Picoprobes with G,S,G configurations and pitches of between 50 and 250 microns. The C and T style Model 67A Picoprobes (see following page for mounting styles) have the same specifications except for insertion loss, which is less than 1.3 db (1.2 db typical).

<sup>2</sup>Crosstalk is measured using two probes contacting a bare sapphire substrate 100 microns apart.

### Model 67A Performance Data<sup>3</sup> G,S & S,G Configuration

Frequency Range: DC to 67 GHz  
 Insertion Loss: Less than 1.0 db to 67 GHz  
 (0.9 db typical)  
 Return Loss: Less than 30 db to 4 GHz  
 Less than 15 db to 26 GHz  
 Less than 12 db to 67 GHz

<sup>3</sup> Specifications are for the P-style Model 67A Picoprobes

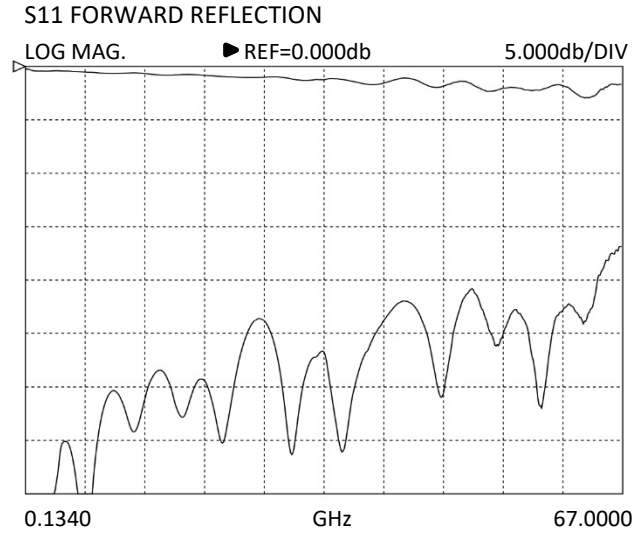
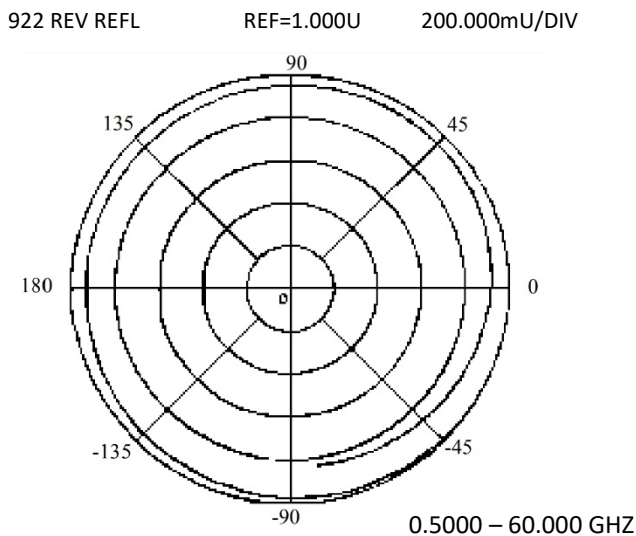

Typical uncalibrated performance of a Model 67A-GSG-150-P Picoprobe. The top trace is the round trip return loss into a short which is twice the probe's insertion loss. The bottom trace is the return loss into a 50 ohm load.

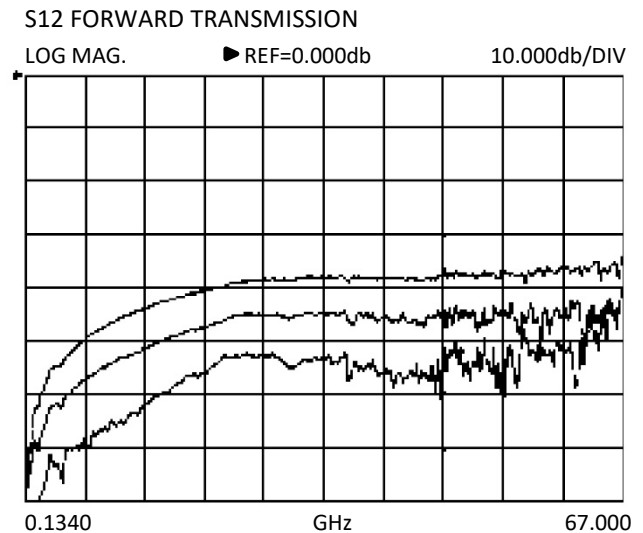

Crosstalk performance of two Model 67A-GSG-150-P Picoprobes while contacting a bare sapphire substrate with spacings of 100, 200, and 400 Microns

**LEFT:** A linear-polar chart showing the calibrated response of a Model 67A-GSG-150-P while contacting a 10 pSec coplanar line. The SOLT method was used for calibration.

❖ **ORDERING INFORMATION**

When ordering Model 50A probes, use the following part numbering convention:

**Model SP-67** \_\_\_\_\_ -- \_\_\_\_\_ -- \_\_\_\_\_  
configuration -- pitch -- mounting style

Configuration: Specify GSG, GS, or SG for tip placement where S is the signal tip and G is a ground tip. Use the following diagram to determine the appropriate configuration.

**TOP VIEW**

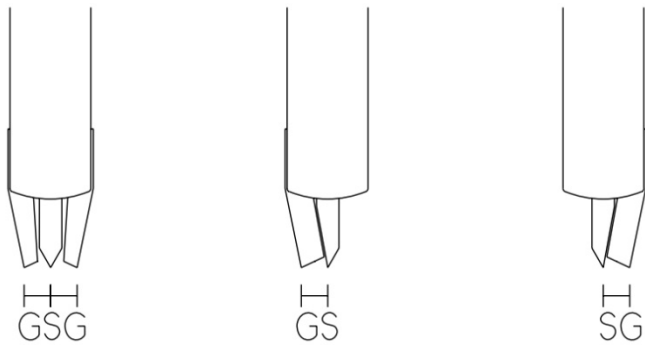

**Pitch:** Specify ground (G) to signal (S) tip spacing in Microns from 50 to 1250 microns. For standard GSG probes, the two spacings are equal. Contact the factory for spacings larger than 1250 microns or unusual tip placement and spacings.

**Mounting Style:** Choose from thirteen adapter styles. Seven of the most common adapter styles are pictured on the right. Specify T, C, GR, P, DP, EDP, LP, Q, F, S, DS, VP, or RVP. Choose the appropriate mounting type for your application. The P, DP, EDP, LP, Q, S, DS, VP, and RVP styles have the connector pointing back at a 45 degree angle to give more working area above the probe. The DP, EDP, DS, VP, and RVP styles are used where extra clearance beneath the probe is needed. When using DP, EDP, and DS style probes, probe positioning is more difficult due to the increased probing angle since the probe points slide further forward for a given change in the Z axis than our other style probes. Custom mounting styles are available.

**Example:** SP-67-GSG-150-P is a Model 67A with Ground, Signal, Ground configuration with 150 microns between each contact mounted in a P style adaptor.

**Right:** Specifications for seven of our most common adapter styles. Please contact our office or visit our web site at: www.signatone.com for information on other adapter styles.

❖ **Mounting Styles and Dimensions**

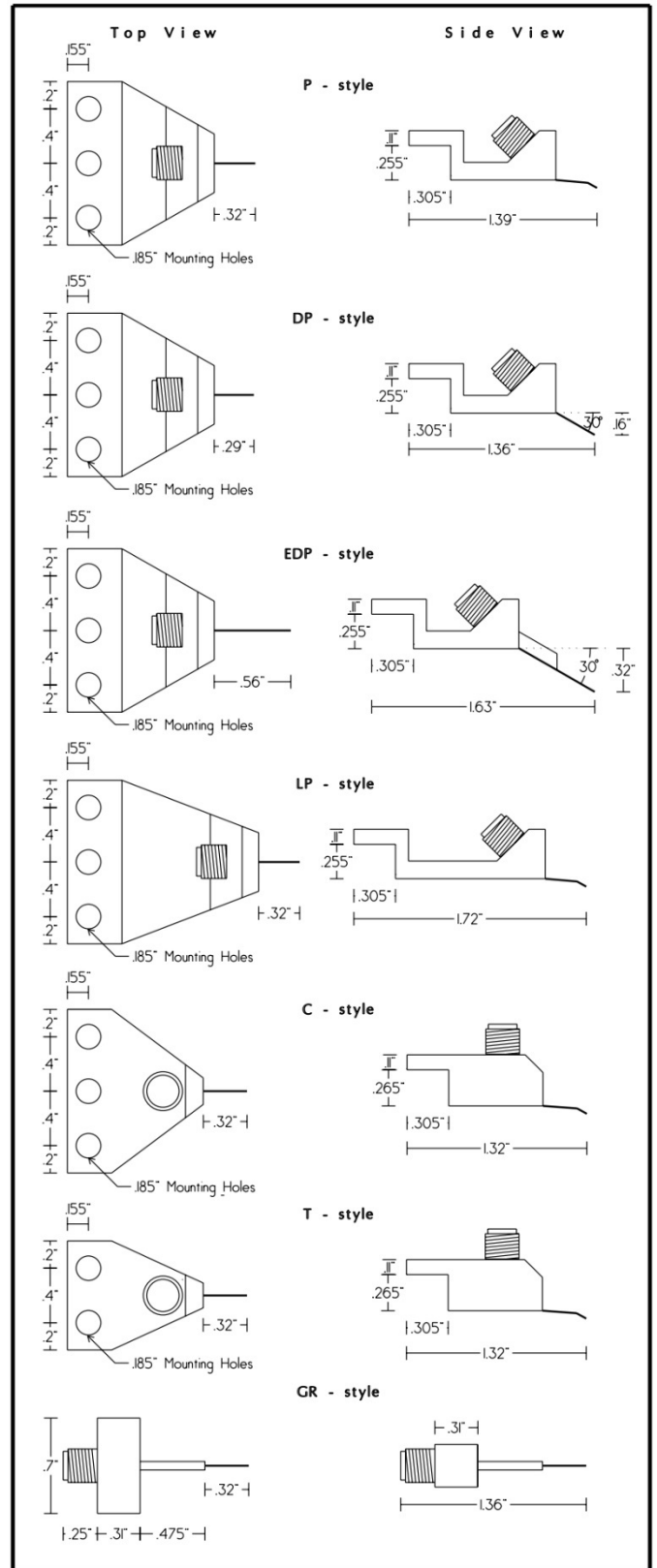

**❖ RF PROBE –SELECTION GUIDE**



**Cable Interface**

	<b>SP-40A</b>	<b>SP-50A</b>	<b>SP-67A</b>	<b>SP-110H</b>	<b>SP-145</b>
<b>Frequency</b>	DC-40GHz	DC-50GHz	DC-67GHz	DC-110GHz	DC-145GHz
<b>Connector</b>	2.92mm	2.4mm	1.85mm	1.0mm	0.8mm
<b>Tip Configuration</b>	GS/SG/GSG	GS/SG/GSG	GS/SG/GSG	GS/SG/GSG	GSG
<b>Pitch Range</b>	50μ - 2540μ	50μ - 1250μ	50μ - 1250μ	50μ - 1250μ	50μ - 200μ
<b>Insertion Loss</b>	<.8db	<1.0db	<1.1db	<1.5db	<1.75db
<b>Return Loss</b>	> 18db	>18db	>14db	>15db	>15db

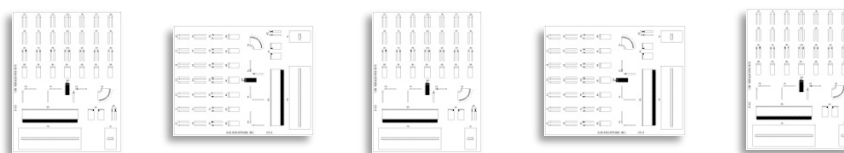

**Calibration Substrates**

<b>GSG</b>	<b>SP-CS-5</b>	<b>SP-CS-9</b>	<b>SP-CS-10</b>	<b>SP-CS-18</b>
Pad Size	50μ X 50μ 100μ X 100μ 150μ X 150μ	100μ X 100μ	150μ X 150μ	300μ X 300μ
Pitch Range	75μ - 250μ	250μ - 600μ	600μ - 1250μ	1250μ - 2540μ

<b>GS/SG</b>	<b>SP-CS-8</b>	<b>SP-CS-14</b>	<b>SP-CS-11</b>	<b>SP-CS-17</b>
Pad Size	50μ X 50μ 100μ X 100μ 150μ X 150μ	100μ X 100μ	150μ X 150μ	300μ X 300μ
Pitch Range	50μ - 200μ	200μ - 400μ	400μ - 1250μ	750μ - 2540μ

<b>GSG &gt; 110GHz</b>	<b>SP-CS-15</b>
Pad Size	25μ X 25μ
Pitch Range	40μ - 150μ (SOLT) 30μ - 150μ (LRM)



**RF Cables**

	<b>RFC-40</b>	<b>RFC-50</b>	<b>RFC-67</b>	<b>RFC-110</b>
<b>Frequency Range</b>	DC - 40GHz	DC - 50GHz	DC - 67GHz	DC - 110GHz
<b>Length</b>	4 Ft.	4 Ft.	3 Ft.	*
<b>Connectors</b>	2.92 M – 2.92 F	2.4 M – 2.4 F	1.85 M - 1.85 F	1.0 M - 1.0 F

\* Contact Factory

### S-M40 Series RF Positioner

**S-M40** Series RF Positioner with 50 TPI linear X-Y-Z motion with in-line precision knobs for quick and accurate positioning of RF probes – great for use with RF and Wedge probe applications DC-110GHz.

An optional "switchable" magnetic base utilizes a neodymium rare-earth magnet. This allows for easy coarse placement of the positioner, which is then locked into place with the simple flip of a lever. Unlike typical magnetic designs, there is no loss of high-frequency performance, due to the strength of the magnetic bond. This extends non-resonant performance to beyond 110 GHz



Travel Range, X, Y, Z	1" (25mm). 40 Turns/inch
Planarization Range: X, Y, Z Resolution:	± 7.50 (.10 Resolution)
Orientation.	E/W (0°) & N/S (90°)
Standard Base: HM	Bolt-Down
Optional Bases: MM	Magnetic (Lever-actuated rare-earth magnet)
OM	Optical table bolt-down base

### Typical Application

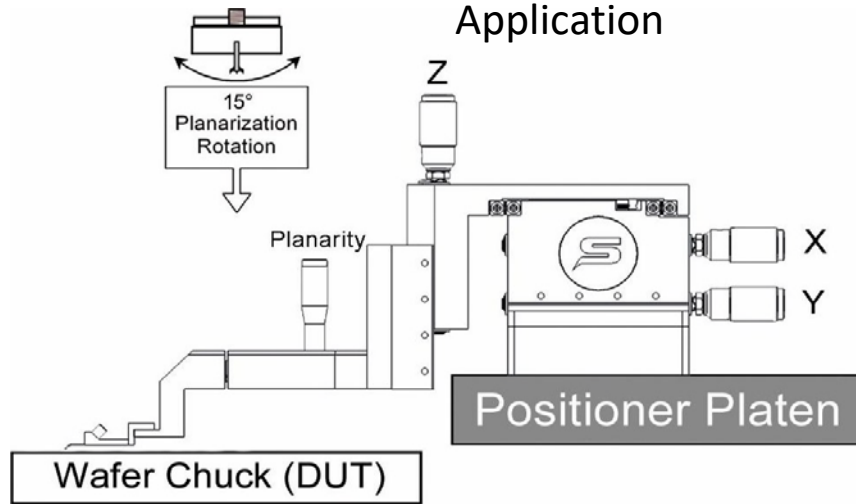

## S-M90 Series RF Positioner

Based on SIGNATONE's highly successful S-M40 design, the Model

S-M90 is intended for users that have requested orthogonal XM control. The use of over-sized cross-roller bearings insures the ultimate in precision and control of probe positioning, while the direct-drive leadscrew design virtually eliminates backlash and hysteresis.



Travel Range, X, Y, Z	1" (25mm). 40 Turns/inch
Planarization Range: X,Y,Z Resolution:	± 7.50 (.10 Resolution)
Orientation.	E/W (0°) & N/S (90°)
Standard Base: HM	Bolt-Down
Optional Bases: MM	Magnetic (Lever-actuated rare-earth magnet)
OM	Optical table bolt-down base

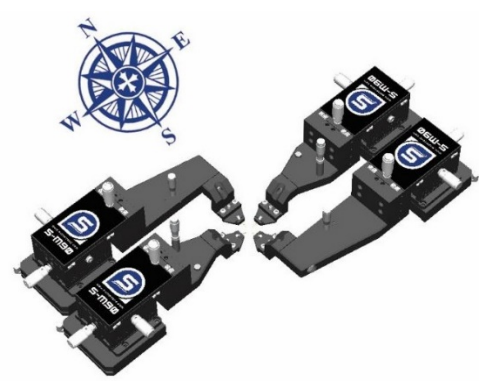
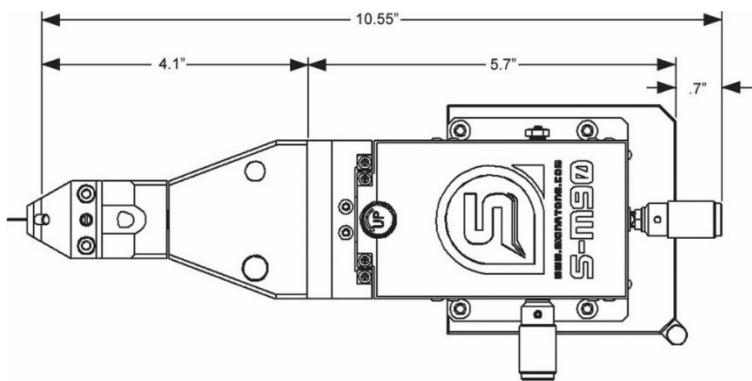

## ❖ WARRANTY

---

- Standard Warranty 12 months \*
- For Extended Warranty and Service Contracts : Contact Signatone Corp. for more information

\* See *Signatone Corporate Terms and Conditions of Sale* for further details.

---

- **North America:** [Sales.NA@signatone.com](mailto:Sales.NA@signatone.com)
- **Europe:** [Sales.Europe@signatone.com](mailto:Sales.Europe@signatone.com)
- **Asia:** [Sales.Asia@signatone.com](mailto:Sales.Asia@signatone.com)
- **Tel:** 1-408-848-2851

