

High Performance Microwave Probes for RF probing

❖ Model SP-120BT

- Durable 75 GHz to 110 GHz
- Insertion loss 1.75 db max (75 to 110 GHz)
- Return loss 15 db max (75 to 110 GHz)
- Individually spring loaded contacts
- Measurement repeatability -50 db
- Bias T option available
- Patented coaxial design



Model SP-120BT (with bias T)

❖ Flexible Tips for Flexible Probing

The PICOPROBE MODEL SP-120BT sets new standards in microwave probing performance. Benefiting from coaxial techniques, which have inherent low loss and low dispersion characteristics, the Signatone offered Model SP-120BT, achieves an insertion loss of less than 1.75 db (typical) and a return loss of greater than 15 db (max.) over its frequency range.

With its individually spring loaded, Beryllium-Copper tips, the Model SP-120BT provides reliable contacts, even when probing non-planar structures. This reliable low resistance contact is one of the keys to providing highly repeatable measurements (-50 db) at W band frequencies. The Model SP-120BT also provides direct viewing of the probe tips for accurate positioning.

Any pitch (tip spacing) from 50 microns to 450 may be specified. The probe can be configured with Ground-Signal-Ground (G,S,G), Ground-Signal (G,S), or Signal-Ground (S,G) tip footprints. We recommend smaller pitches with a G,S,G footprint for best performance.

Model 120BT Performance Data

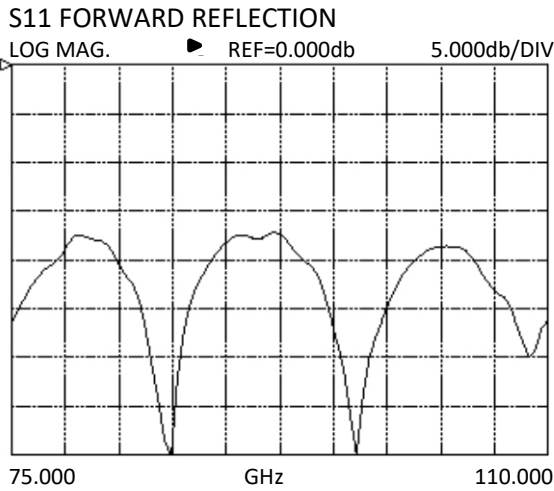

Typical uncalibrated performance of a Model SP-120BT-GSG-150 while touching a 50 Ohm load on our CS-5 Calibration Substrate.

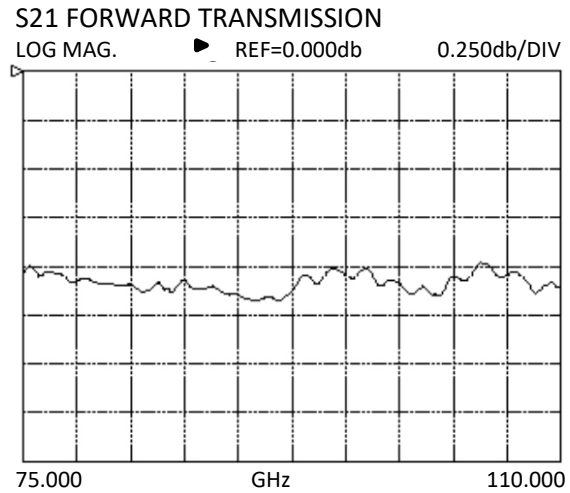

Typical insertion loss of a Model SP-120BT-GSG-150.

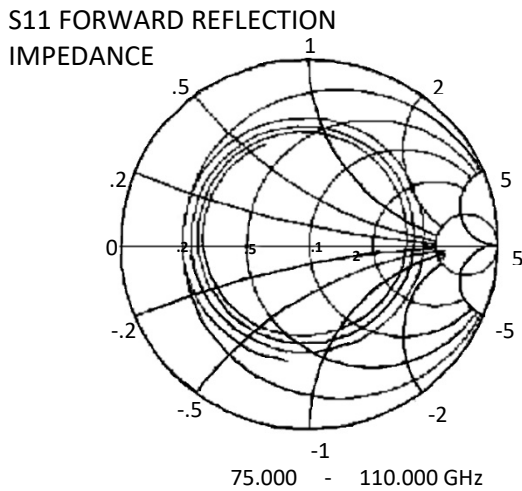

Forward reflection of a Model SP-120BT into an open ended 50 ps coplanar line after an LRM/TRM calibration was performed using our CS-5 Calibration Substrate. The smooth inwardly spiraling line shows the increasing loss of the 50 ps coplanar line with frequency, coupled with a smoothly changing phase. The CS-5 Calibration Substrate will also perform excellent LRL/TRL and SOLT W-band calibrations.

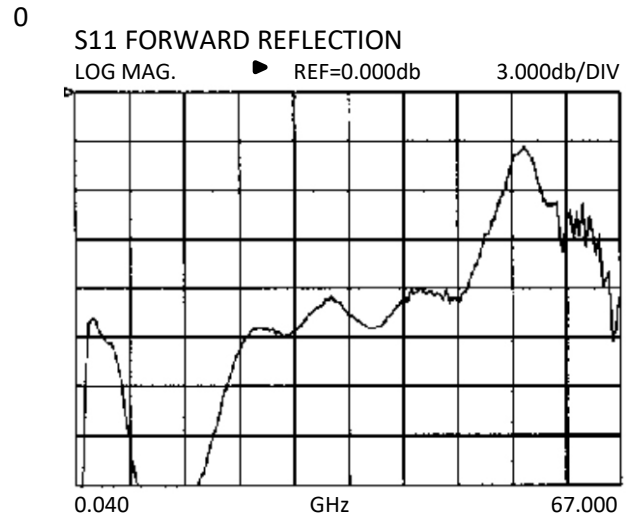

The Model SP-120BT's Bias T provides a direct low resistance DC path for supplying up to 1.5 A to a device under test. The Bias T has special circuits which add loss at frequencies below the cut-off frequency (59.05 GHz) of WR-10 waveguide. This data was taken by launching a 40 MHz to 67 GHz signal from the tips of a calibrated Model 67A into the tips of a Model 120-GSG-150-BT. Without this low frequency loss, most active devices will oscillate.

❖ **Probe Mounting and Dimensions**

Model SP-120BT
75GHz -110GHz
Microwave Probe

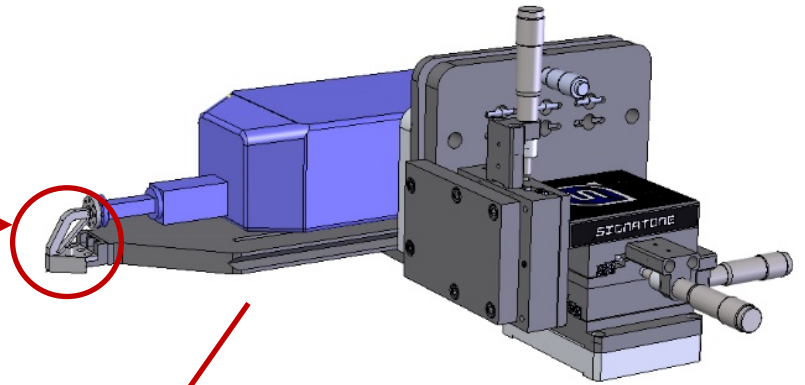
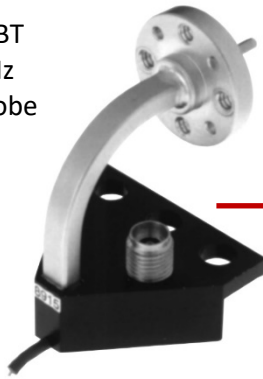

Signatone S-LAP-90 Large Area Positioner for mounting 50-1100GHz probes directly to the Frequency Extender with wave guide.

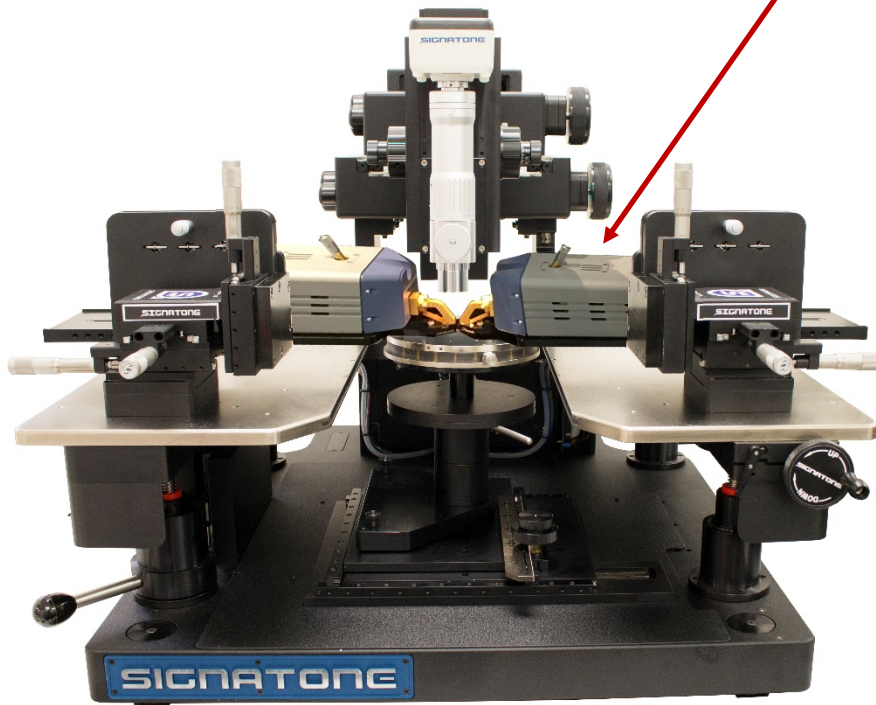

Micropositioners are available to hold virtually all the current models of Frequency extenders and tuners modules so that the module and the probe are moved and positioned as a unit (together). In this way, total ease of positioning can be achieved with minimum insertion loss.

Image Left: Shows WaveLink 170-THZ probe station with East & West S-LAP-90 Positioners, 325 GHz probes attached to Frequency Extenders.

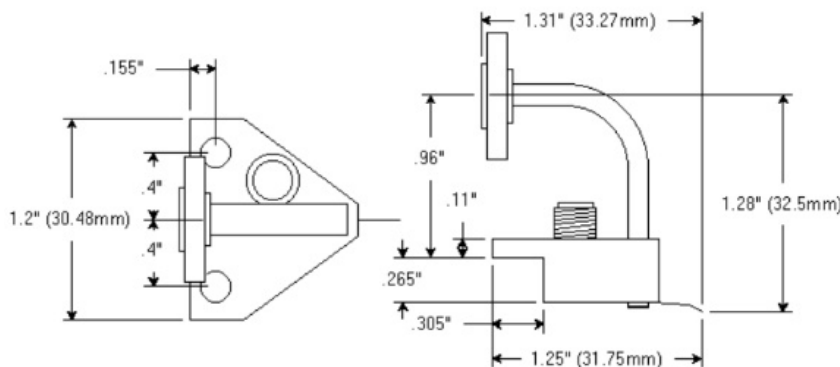

Model SP-120BT Waveguide

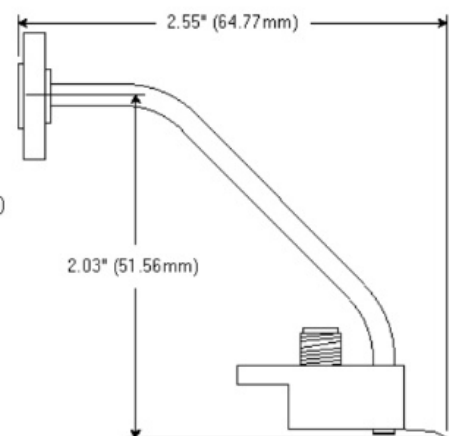

Model SP-120BT-M Waveguide Dimensions

❖ WARRANTY

- Standard Warranty 12 months *
- For Extended Warranty and Service Contracts : Contact Signatone Corp. for more information

* See *Signatone Corporate Terms and Conditions of Sale* for further details.

- **North America:** Sales.NA@signatone.com
- **Europe:** Sales.Europe@signatone.com
- **Asia:** Sales.Asia@signatone.com

