

Signatone Multi Purpose Probe Tips

❖ Model SE-T

- Material-Tungsten
- Point /Tip - Diameter = 5μ
- Length = 31.75mm / 1.25"
- Shank Diameter = 0.63mm
- Fabrication - Precision Ground
- Typical Use - 5μ to 100μ Pad - Metal
- Typical Test – General

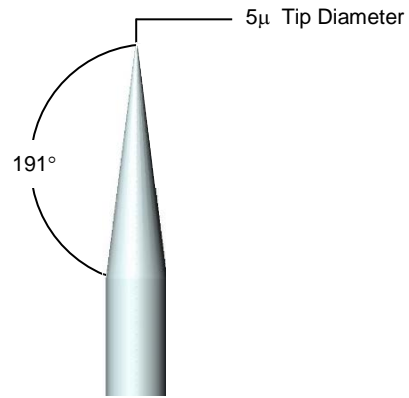

❖ A Tip for Every Test

Model SE-T (Ground Tip)

Offering a wide variety of passive probe tips to suit virtually every probing requirement.

The most common style probe tip (referred to as "Hard-TIP") includes a taper or angle from the probe shaft to the tip. This effect is achieved by etching or a grinding process on the material allowing more mass at the tip end. (recommended for probing through passivation or hard materials)

The SE-T is a general-purpose probe tip made with a 31.75mm /1.25" long, 0.63mm diameter tungsten wire that has been precision ground down to 5μ (micron). The shank may be bent into a variety of shapes to meet the most complex probing configurations. This is our widely used "precision ground tip" and is typically used for general probing. Typical: 5μ to 100μ lines and pads

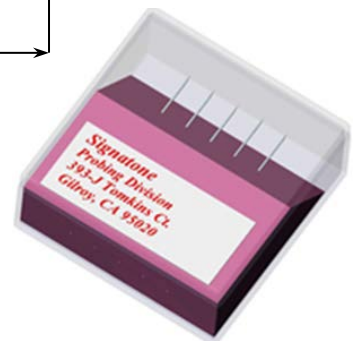
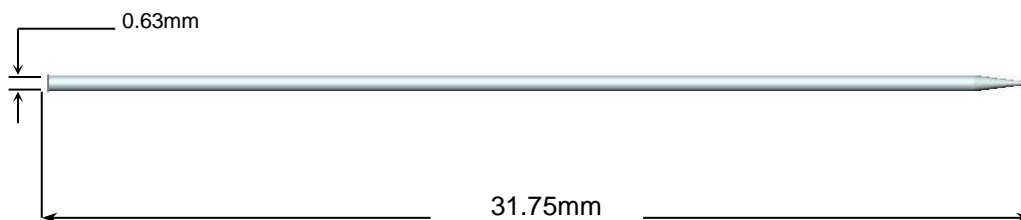

Tips are sold by the box including quantity of 5 tips

❖ WARRANTY

- Standard Warranty 12 months *
- Note: Probe Tips, Probe Tip Holders, and 4-Point Probe Heads are considered consumable items and are not covered under the standard warranty

** See Signatone Corporate Terms and Conditions of Sale for further details.*

- **North America:** Sales.NA@signatone.com
- **Europe:** Sales.Europe@signatone.com
- **Asia:** Sales.Asia@signatone.com

